



CITY OF VINCENT

LIGHTBOX

LANEWAY GALLERY

» INFORMATION FOR EXPRESSIONS OF INTEREST

The City acknowledges the importance of public art and the role it plays in meeting its strategic objective to celebrate, acknowledge and promote the City's cultural and social diversity. The aim of the Lightbox Laneway Gallery is to provide a public exhibition space to showcase artists, and provide the community with an accessible gallery.

8 lightbox cabinets are located in the laneway between St Michael's Restaurant and Orno Interiors, near 483 Beaufort Street, Highgate. The City provides the opportunity for artists to utilise the lightboxes to exhibit for 3 months, providing a new exhibition 4 times a year.

This document provides information and guidelines to local artists, groups of artists and curators who wish to submit a Lightbox Laneway Gallery exhibition proposal with a budget of \$1,000.

Applicants should be proficient in envisioning, writing about and installing an exhibition. Proposals should be conceptually resolved and supported by a visual mock up alongside examples of past works and submitted to mail@vincent.wa.gov.au by the closing date provided. Preference will be given to those artists who reside in the City of Vincent.

» LIGHTBOX DIMENSIONS AND FITTINGS

Proposals should address all 8 lightboxes with 4 being portrait, and four landscape. The display areas are A2 (594mm x 420mm) with a 100mm depth. The City recommends dedicating 1 lightbox to artist information, and directing the community to purchase the works, or to find out more about the artist.

Print works are secured by strong magnet strips within the display cases. Diagrams are found in **Appendix 1**.

Each lightbox is lit internally with energy efficient LED lights, which are solar powered.



Lightbox Artwork by: Ruby Smedley. Mural by: Drew Straker. Photo by: The Rabbit Hole

» MATERIALS

All materials installed in the lightboxes must be of professional quality and be able to be removed without compromising the integrity of the lightbox or its fittings. Materials should not damage the lightboxes in any way, or be materials that may rot or deteriorate.

Given the public location of the lightboxes, applicants are encouraged to carefully consider their choice of installation materials. It is suggested artists should not plan to use rare, valuable, precious or irreplaceable materials. Prints, opposed to original artwork are also suggested, and non-adhesive transparency film prints work best with the lighting.

» INSTALLATION PROCESS

The artist/s will meet City's Officers on-site to install works at an agreed time. The artist is to liaise with the City to ensure that any approvals required are met. It is the responsibility of successful artist is to maintain a safe working environment.

The City will remove the works when the next exhibition is installed and advise the artist when their works are ready to be collected from the City.

» THE COMMISSION

The Lightbox Laneway Gallery provides opportunities for artists or groups of artists to showcase their art practice in the public realm, or for emerging curators to propose an exhibition featuring artists for the space.

Proposals should respond to the space in a contemporary manner. Applications will be assessed based on:

- » the exhibition rationale;
- » demonstration of artistic excellence and innovation of the works proposed; and
- » quality of previous artworks (supported by image submission).

The ambition of each exhibition is to achieve maximum impact with minimum risk to the work, surroundings and public. All artwork and imagery is to be G rated and to contain no offensive material.

» **ELIGIBILITY**

This commission is targeted at local artists and additional consideration will be given to emerging artists seeking to develop their profile and skills.

» **BUDGET**

The commission is \$1,000 (ex GST). There will be 4 commissions over the year, each lasting 3 months.

The budget should cover all costs related to the development, marketing and installation of the work, including but not limited to artist fees, production fees and materials. The budget can also go towards a small exhibition launch event, organised by the artist and approved by the City.

Costs related to travel, accommodation, travel insurance and public liability insurance will not be covered by the commission.

It is encouraged that artworks, or reproduced prints, be for sale. The City will not take any commission of these sales.

Selected applicants will be paid as per the following:

- » 70% of the fee upon signing of an agreement; and
- » 30% upon completion of the exhibition.

» **OSH**

It's the artist's duty to maintain a safe working environment and immediately report to the City any issues that may arise on site. They must supervise any assistants or tradesman they have engaged. When hiring equipment, they must ensure all appropriate OSH standards are met.

Note: The City of Vincent may choose to provide the lead artist or curator with an induction and then require them to provide that information to artists and/or sub-contractors.

» **INSURANCE**

The Laneway Lightbox Gallery is insured as part of the City of Vincent's public art register. For insurance purposes, a list of installation components and values are to be supplied to the City prior to installation.

» **COPYRIGHT**

The City reserves the right to document, reproduce or otherwise use any artwork submitted for Lightbox Laneway Gallery for purposes associated with Lightbox Laneway Gallery, without charge.

The City will acknowledge the Artist as the author of the Artwork and recognise the Moral Rights of the Artist in accordance with the Copyright Act 1968.

The Artist agrees that the copyright in all artworks created in the course of the contract remain the property of the artist. The Artist shall give the City a non-exclusive licence to reproduce the images for related non-commercial purposes including publicity and promotion of the event/project, education and record keeping.

The Artist warrants that the Artworks and any Intellectual Property supplied by the Artist and embodied or used in connection with the Artwork is the sole property of the Artist or the Artist is legally entitled to use the Intellectual Property for the provision of the Artwork.

» **ENQUIRIES**

All enquiries should be directed to the City's Arts and Activation Officer on 9273 6000 or email mail@vincent.wa.gov.au

» APPENDIX 1

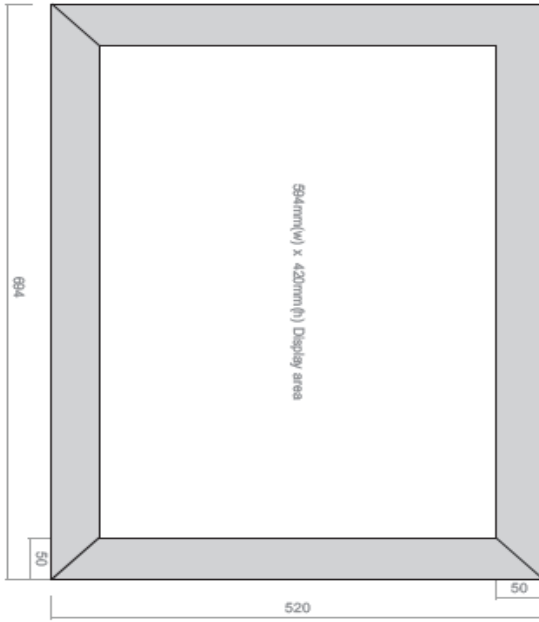

Landscape Front Display Elevation

- A2(594mm x 420mm) display area.
- Unfinished face - patterned metallic appearance

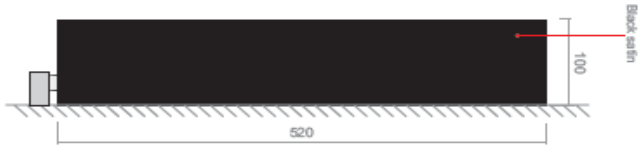

Landscape Side Elevation

- Colour applied to sides only. Sample to be supplied
- sanded face black return

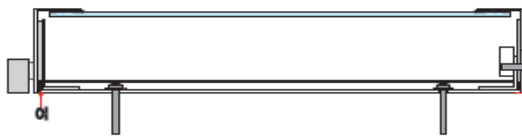

Side Elevation Cutaway

Refer to arrangement page 004

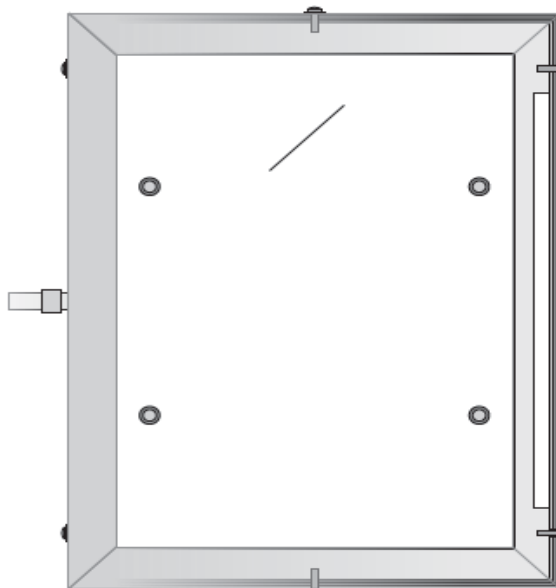

Front Display Cutaway



Landscape Front Display Elevation

- A2(594mm x 420mm) display area.
- Unfinished face - patterned metallic appearance

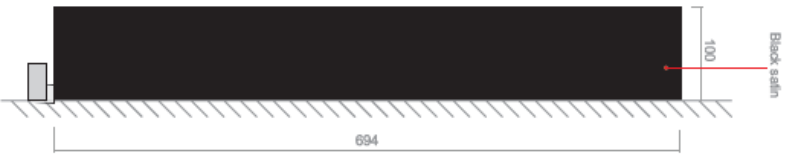

Landscape Side Elevation

- Colour applied to sides only. Sample to be supplied
- sanded face black return

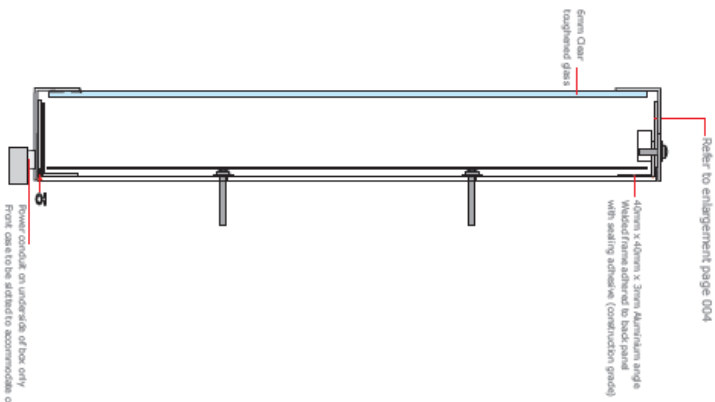

Side Elevation Cutaway

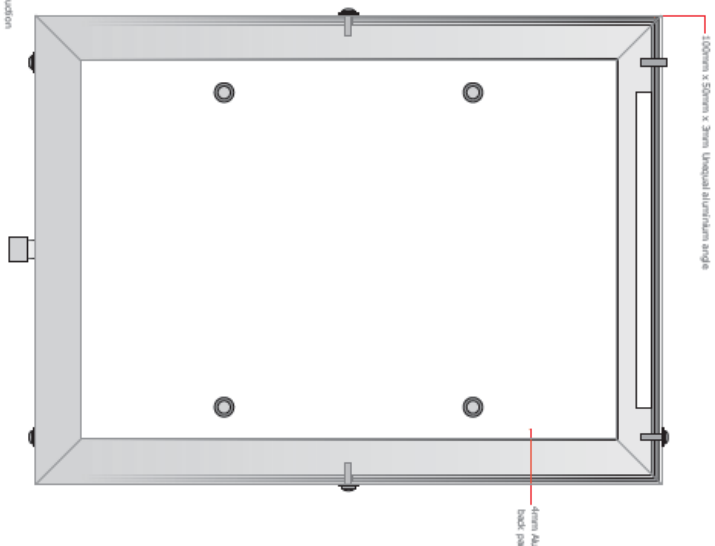

Front Display Cutaway

Front panel on underside of box only
Front case to be adhered to accommodate conduit obstruction

